



Genesis

• Precision performance • Maximum reliability • Extraordinary value

Leaders in compression molding
and laminating presses for over half a century

Perforated steel panel safety guards in an extruded aluminum frame
improved safety for operator and bystanders

Stress-proof tie rods
adjustable daylight

Solid steel bolsters
minimize deflection

Automatic platen cooling*
(not shown) faster platen cool-down

Stainless steel cooling hoses*
(not shown) improved durability

Heated platen package*
for molding and laminating applications

Double-acting JIC-style hydraulic cylinder
power in both directions

Unitized steel base with convenient slots for lifting forks
easy and safe installation

Digital temperature controller for each platen*
accurate platen temperature control

NEMA-rated control enclosure

Operator interface for programming of press functions
user-friendly controls

Operating buttons and switches

4" force gauge
displays clamp force

Clamp pressure relief valve
precise adjustment of operating force

Pressing speed control*
(not shown) adjustment of slow closing speed

Self-contained hydraulic unit
quiet reliable operation

* Indicates optional equipment

Hydraulic presses available in 15 to 150 ton models
with single or multiple openings.

Genesis standard features you want and options your applications may require

Genesis Series presses are state-of-the-art hydraulic presses for compression molding of rubber, plastics and composites; and for laminating and bonding or a pressure application where positive ram control is needed. The Genesis Series reflects more than a half a century of WABASH leadership in hydraulic press design and construction. It is rugged enough for round-the-clock performance on the production floor, but works equally well as a precision laboratory press.

Standard Features:

- Adjustable clamp force: 15 to 150 tons
- Platen size: 12" x 12" to 30" x 30"
- Programmable controller with access module
- Automatic transfer from closing to pressing speed
- Closing speed 70-90 IPM
- Pressing speed 5 IPM
- OSHA approved operating system
- Pressure adjustment valve
- Integral hydraulic system with high-efficiency TEFC motor, reservoir, gauge and water-cooled heat exchanger
- Electrical supply: 460/3/60 (other voltages available)

See front page photo for additional standard design and construction features.

Optional Features:

- Larger platen sizes
- Special control systems
- Heated platens (to 500°F, 650°F, 800°F, 1200°F or 1800°F) with cartridge heaters
- Digital PID temperature controllers
- Low pressure system
- Water cooled platens
- Multiple daylights (consult WABASH for information on special requirements your application may demand)
- Pressing speed control
- Automatic bump "breathe" sequence
- CE certification available

Genesis presses are available in 15 through 150 ton capacities. The hydraulic system produces faster closing and opening speeds, making it ideal for use with many of today's advanced molding compounds. Optional heated platens are available for 500°F, 650°F, 800°F, 1200°F and 1800°F operating temperatures, which are required for many composite, ceramic and other molding applications, including superplastic molding of titanium.



Energy-efficient Hydraulic System

Integral hydraulic system features a dual pump assembly coupled with a high-efficiency TEFC motor sized for the press. Components are easily accessible for quick maintenance.

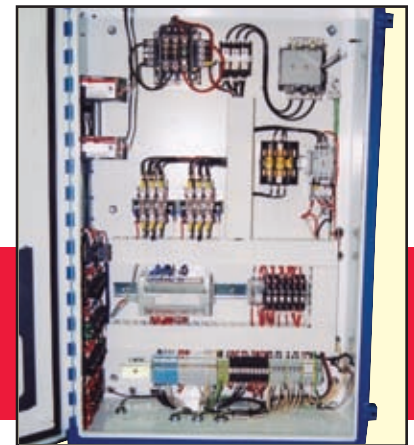

Reliable Control Systems

NEMA-rated control cabinet designed for easy access. All electrical panels manufactured by WABASH MPI in our UL-approved electrical shop. (UL listing on panels optional.)

Enhanced Controls

Packages available for proportional control of pressure, position and temperature. Programmable through a touch screen.



Specifications for WABASH Genesis Series Hydraulic Presses



Unheated Models	Heated Platen Models	Clamp Force (US tons)	Clamp Cylinder Bore (in)	Clamp Stroke (in)	Platen Size (in)	Tie Rod Diameter (in)	Dimensions (in)					Current Draw @ 460/3/60 (Amps)		Approx. Weight (lbs)	
							A	B	C*		D	E	Unheated		Heated Platens
									Std.	Heated					
G15-12	G15H-12	15	5	6	12 x 12	1.25	42	40	10-18	6-12	72	42	4	14	1,750
G15-15	G15H-15				15 x 15									18	1,850
G30-12	G30H-12	30	5	6	12 x 12	1.25	42	40	10-18	6-12	72	42	4	14	1,750
G30-15	G30H-15				15 x 15									18	1,850
G30-18	G30H-18				18 x 18									25	2,500
G50-15	G50H-15	50	7	8	15 x 15	2.0	50	46	12-22	8-16	77	42	6	19	3,500
G50-18	G50H-18				18 x 18									27	3,700
G50-24	G50H-24				24 x 24		36	5,500							
G75-15	G75H-15	75	8	8	15 x 15	2.0	52	52	12-22	8-16	87	42	10	25	3,800
G75-18	G75H-18				18 x 18		35	5,500							
G75-24	G75H-24				24 x 24		40	8,000							
G100-18	G100H-18	100	10	12	18 x 18	3.0	54	53	16-28	12-22	83	42	12	32	6,500
G100-24	G100H-24				24 x 24		42	7,000							
G150-30	G150H-30	150	12	12	30 x 30	3.0	66	60	16-28	12-22	86	43	12	57	10,000
ASTM SAMPLE PREPARATION MODELS															
N/A	G30H-ASTM	30	5	6	12 x 12	1.25	43	40	N/A	6-12	81	42	N/A	13	1,850
	G302H-ASTM				93						23			2,150	

* Platen cooling may reduce daylight by 1 to 2 inches. Consult factory for specific requirements.

All new WABASH presses are manufactured in compliance with current regulations and are furnished with safety guards as standard equipment. Guards may have been removed in some photographs for clarity. WABASH strongly recommends use of guards and personal protection equipment when operating any press. As a result of continuous improvement, specifications are subject to change without notice. Consult factory for specific data and pricing.

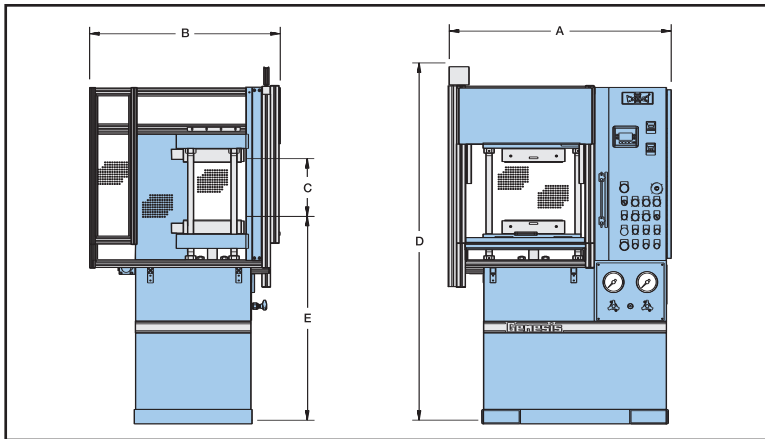

*Platen Temperature
Controllers*

Standard 1/16th DIN platen temperature controllers.



**Three-Daylight
30 Ton Press**

Features 12" x 12" fully guided heated platens, perimeter light curtain, casters, automatic low pressure, and pressing speed control. The press is suitable for use in a class 10,000 clean room.



Large Genesis Series Press

ViewPoint™ control system and high-temperature guard package.

Customized Genesis Presses

While standard WABASH Genesis Presses handle a broad range of applications and can be upgraded with available options, your unique requirements may call for a "customized" press. Shown on this page are a number of such machines which have provided solutions for our customers' problems. Consult your WABASH representative or our office for more information about "customization" for your particular needs.

**Electric
Compression
Molding Press**

All-Electric presses available in a clamping force of up to 30 tons. Suited for both production and lab environments. Clean and quiet operation, improved energy-efficiencies and greater precision/reliability over hydraulic presses.



**Plastic ASTM
Test Sample
Molding Press**

Genesis model G30H-ASTM is designed to produce polyethylene test samples in accordance with ASTM D4703, Procedure C. Models for rubber test samples (ASTM D3182) also available.



WABASH MPI

1569 Morris Street, P.O. Box 298
Wabash, Indiana 46992-0298 U.S.A.
Phone 260-563-1184 • FAX 260-563-1396
E-mail: wabashmpi@corpemail.com
Internet: www.wabashmpi.com

**ISO 9001:2008
Registered**

